

User's guide

SMA5 + MTA5

Absolute linear encoder

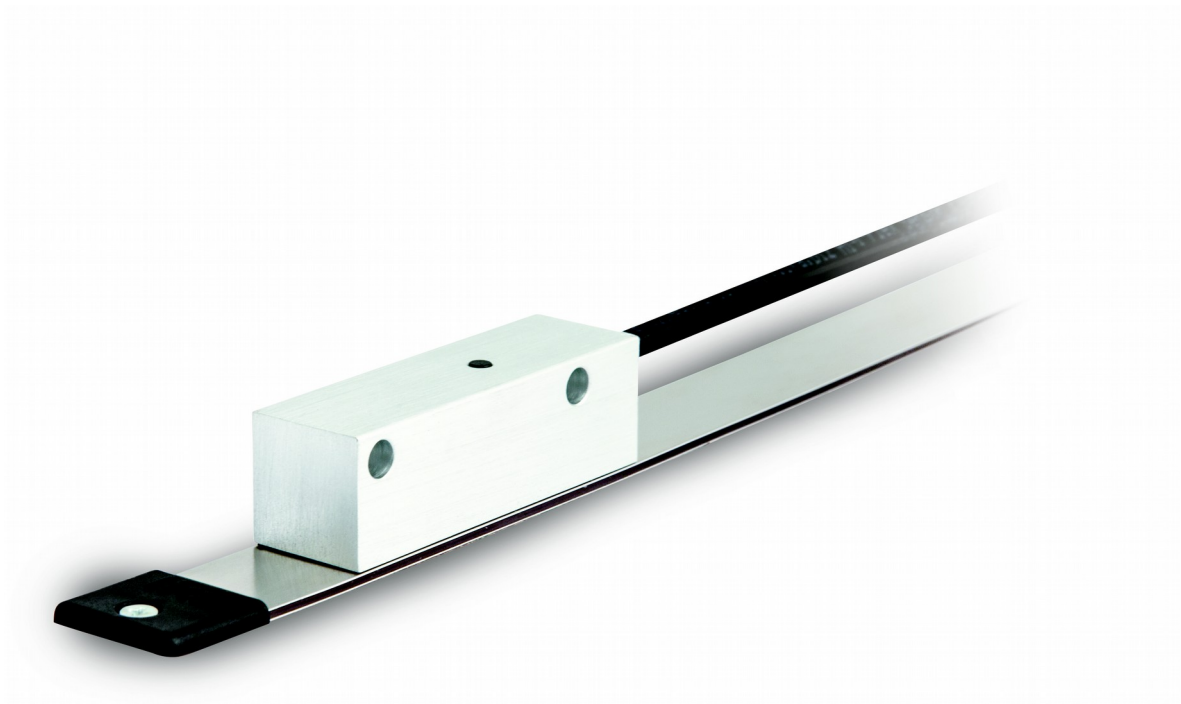

lika

Smart encoders & actuators

This publication was produced by Lika Electronic s.r.l. 2016. All rights reserved. Tutti i diritti riservati. Alle Rechte vorbehalten. Todos los derechos reservados. Tous droits réservés.

This document and information contained herein are the property of Lika Electronic s.r.l. and shall not be reproduced in whole or in part without prior written approval of Lika Electronic s.r.l. Translation, reproduction and total or partial modification (photostat copies, film and microfilm included and any other means) are forbidden without written authorisation of Lika Electronic s.r.l.

The information herein is subject to change without notice and should not be construed as a commitment by Lika Electronic s.r.l. Lika Electronic s.r.l. reserves the right to make all modifications at any moments and without forewarning.

This manual is periodically reviewed and revised. As required we suggest checking if a new or updated edition of this document is available at Lika Electronic s.r.l.'s website. Lika Electronic s.r.l. assumes no responsibility for any errors or omissions in this document. Critical evaluation of this manual by the user is welcomed. Your comments assist us in preparation of future documentation, in order to make it as clear and complete as possible. Please send an e-mail to the following address info@lika.it for submitting your comments, suggestions and criticisms.

The logo for Lika Electronic s.r.l. consists of the word "lika" in a bold, lowercase, sans-serif font. The letter "i" has a dot, and the letter "a" has a tail that curves slightly to the right. The logo is positioned in the bottom right corner of the page.

General contents



User's guide.....	1
General contents.....	3
Typographic and iconographic conventions.....	4
Preliminary information.....	5
1 - Safety summary.....	6
1.1 Safety.....	6
1.2 Electrical safety.....	6
1.3 Mechanical safety.....	7
2 - Identification.....	7
3 - Mounting instructions.....	8
3.1 Overall dimensions.....	8
3.2 Magnetic scale.....	8
3.3 Mounting the sensor.....	9
4 - Electrical connections.....	11
4.1 M12 8-pin connector specifications.....	11
4.2 M8 cable specifications.....	11
4.3 Ground connection.....	12
4.4 Zero setting.....	12
4.5 Counting direction.....	12
4.6 Features summary.....	13
5 - SSI interface.....	14
5.1 SSI (Synchronous Serial Interface).....	14
5.2 LSB right aligned protocol.....	15
5.3 Recommended transmission rates.....	16
6 - Error and fault diagnostics.....	17
6.1 Diagnostic LED.....	17
7 - Maintenance.....	18
8 - Troubleshooting.....	19

Typographic and iconographic conventions

In this guide, to make it easier to understand and read the text the following typographic and iconographic conventions are used:

- parameters and objects both of the device and the interface are coloured in **GREEN**;
- alarms are coloured in **RED**;
- states are coloured in **FUCSIA**.

When scrolling through the text some icons can be found on the side of the page: they are expressly designed to highlight the parts of the text which are of great interest and significance for the user. Sometimes they are used to warn against dangers or potential sources of danger arising from the use of the device. You are advised to follow strictly the instructions given in this guide in order to guarantee the safety of the user and ensure the performance of the device. In this guide the following symbols are used:

	This icon, followed by the word WARNING , is meant to highlight the parts of the text where information of great significance for the user can be found: user must pay the greatest attention to them! Instructions must be followed strictly in order to guarantee the safety of the user and a correct use of the device. Failure to heed a warning or comply with instructions could lead to personal injury and/or damage to the unit or other equipment.
	This icon, followed by the word NOTE , is meant to highlight the parts of the text where important notes needful for a correct and reliable use of the device can be found. User must pay attention to them! Failure to comply with instructions could cause the equipment to be set wrongly: hence a faulty and improper working of the device could be the consequence.
	This icon is meant to highlight the parts of the text where suggestions useful for making it easier to set the device and optimize performance and reliability can be found. Sometimes this symbol is followed by the word EXAMPLE when instructions for setting parameters are accompanied by examples to clarify the explanation.

Preliminary information

This guide is designed to provide the most complete and exhaustive information the operator needs to correctly and safely install and operate the **SMA5 series absolute linear encoder**. SMA5 is designed to measure displacements in industrial machines and automation systems. The measurement system includes a magnetic tape and a magnetic sensor with conversion electronics. The scale is magnetized with a coded sequence of North-South poles generating an absolute pattern. As the encoder moves along the magnetic scale, the sensor detects the displacement and yields the absolute position information through the SSI interface (order code SMA5-GA-...).

It is mandatory to pair the sensor with the **MTA5 type magnetic tape**.

To make it easier to read and understand the text, this guide can be divided into two main sections.

In the first section some general information concerning the safety, the mechanical installation and the electrical connection as well as tips for setting up and running properly and efficiently the unit are provided.

In the second section, entitled **SSI interface**, both general and specific information is given on the SSI interface.

1 - Safety summary



1.1 Safety

- Always adhere to the professional safety and accident prevention regulations applicable to your country during device installation and operation;
- installation and maintenance operations have to be carried out by qualified personnel only, with power supply disconnected and stationary mechanical parts;
- device must be used only for the purpose appropriate to its design: use for purposes other than those for which it has been designed could result in serious personal and/or the environment damage;
- high current, voltage and moving mechanical parts can cause serious or fatal injury;
- warning ! Do not use in explosive or flammable areas;
- failure to comply with these precautions or with specific warnings elsewhere in this manual violates safety standards of design, manufacture, and intended use of the equipment;
- Lika Electronic assumes no liability for the customer's failure to comply with these requirements.



1.2 Electrical safety

- Turn OFF power supply before connecting the device;
- connect the unit according to the explanation in the "4 - Electrical connections" section;
- the wires of unused signals must be cut at different lengths and insulated singularly;
- connect Zero setting and Counting direction inputs to 0Vdc, if not used;
 - to zero set the encoder, connect the Zero setting input to +Vdc for 100 μ s at least, then disconnect +Vdc; normally voltage must be at 0Vdc; zero setting must be performed after Counting direction; we suggest performing the zero setting when the encoder is in stop;
 - Counting direction (see the "3 - Mounting instructions" section): increasing count = connect to 0Vdc; decreasing count = connect to +Vdc;
- in compliance with 2004/108/EC norm on electromagnetic compatibility, following precautions must be taken:
 - before handling and installing the equipment, discharge electrical charge from your body and tools which may come in touch with the device; 
 - power supply must be stabilized without noise; install EMC filters on device power supply if needed; T or P type LC filters are often adequate;
 - always use shielded cables (twisted pair cables whenever possible);
 - avoid cables runs longer than necessary;
 - avoid running the signal cable near high voltage power cables (e.g. drive cables);
 - install the device as close as possible to the electronic control unit;
 - mount the device as far as possible from any capacitive or inductive noise source; shield the device from noise source if needed;

- mount the device as far as possible from the inverter (if installed in the machine); shield the device if needed;
- to guarantee a correct working of the device, avoid using strong magnets on or near by the unit;
- minimize noise by connecting the cable shield and/or the connector housing and/or the sensor to ground. Make sure that ground is not affected by noise. The connection point to ground can be situated both on the device side and on user's side. The best solution to minimize the interference must be carried out by the user.



1.3 Mechanical safety

- Install the device following strictly the information in the "3 – Mounting instructions" section;
- mechanical installation has to be carried out with stationary mechanical parts;
- do not disassemble the unit;
- do not tool the unit;
- delicate electronic equipment: handle with care; do not subject the device to knocks or shocks;
- protect the unit against acid solutions or chemicals that may damage it;
- respect the environmental characteristics of the product;
- we suggest installing the unit providing protection means against waste, especially swarf as turnings, chips, or filings; should this not be possible, please make sure that adequate cleaning measures (as for instance brushes, scrapers, jets of compressed air, etc.) are in place in order to prevent the sensor and the magnetic scale from jamming.

2 – Identification

Device can be identified through the **order code** and the **serial number** printed on the label applied to its body. Information is listed in the delivery document too. Please always quote the order code and the serial number when reaching Lika Electronic for purchasing spare parts or needing assistance. For any information on the technical characteristics of the product refer to the technical datasheet.



Warning: devices having order code ending with "/Sxxx" may have mechanical and electrical characteristics different from standard and be supplied with additional documentation for special connections (Technical Info).

3 – Mounting instructions



WARNING

Installation has to be carried out by qualified personnel only, with power supply disconnected and mechanical parts compulsorily in stop.

3.1 Overall dimensions

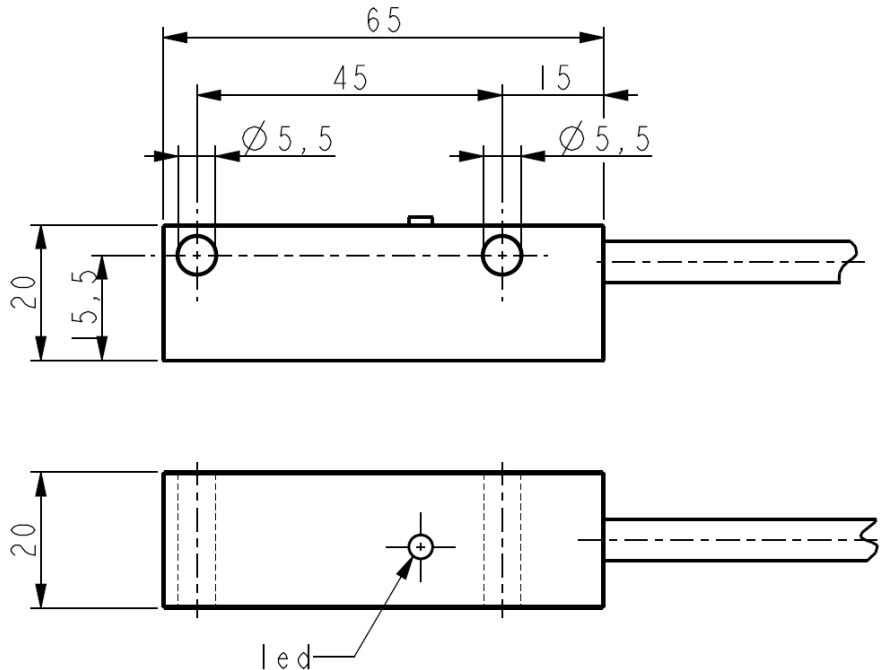

3.2 Magnetic scale

The sensor has to be paired with the **MTA5 type magnetic scale** only. For detailed information on the MTA5 type scale and how to mount it refer to the specific technical documentation.

Install the unit providing protection means against waste, especially swarf as turnings, chips, or filings; should this not be possible, please make sure that adequate cleaning measures (as for instance brushes, scrapers, jets of compressed air, etc.) are in place in order to prevent the sensor and the magnetic scale from jamming.

Make sure the mechanical installation meets the system's requirements of distance, planarity and parallelism between the sensor and the scale indicated in Figure 2 all along the whole measuring length.

MTA5 magnetic scale can be provided with a cover strip to protect its magnetic surface (see the order code).

The Figure 1 shows how the sensor and the scale must be installed; the arrow indicates the **standard counting direction** (increasing count, see on page 12).



WARNING

The system cannot work if mounted otherwise than illustrated in Figure 1.

3.3 Mounting the sensor

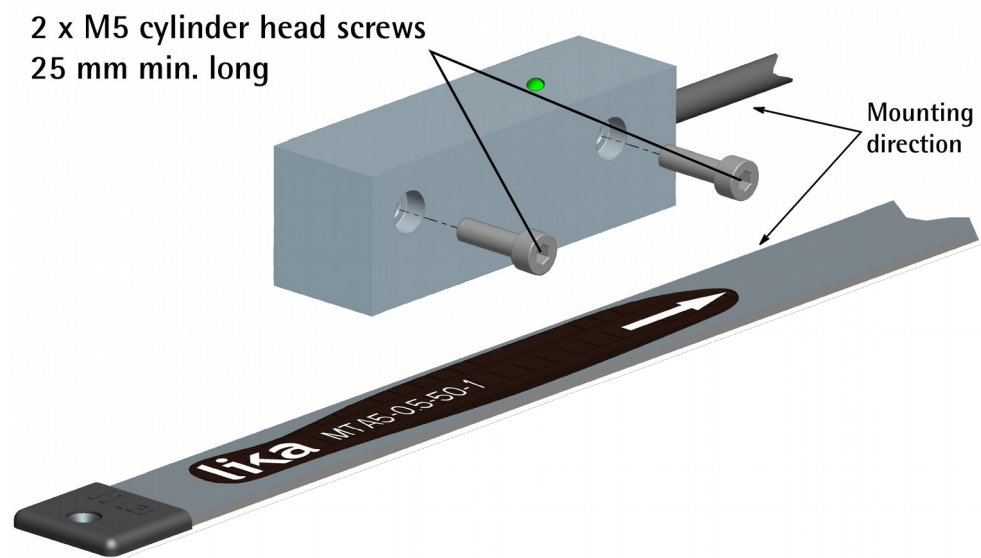

Figure 1

Make sure the mechanical installation complies with the system requirements concerning distance, planarity and parallelism between the sensor and the scale. Avoid contact between the parts. Sensor is fixed by means of **two M5 25 mm min. long cylinder head screws** inserted in the provided holes. Recommended **minimum bend radius** of the cable: **$R \geq 42 \text{ mm}$** .

Please note that the MTA5 magnetic scale can be provided with a cover strip to protect its magnetic surface (see the order code). Therefore the distance between the sensor and the magnetic scale is different whether the cover strip is applied.

The allowed gap D (see Figure 2) between the sensor and the scale must be in the range indicated in the following table:

Gap sensor / MTA5 magnetic scale (D)	
without cover strip	with cover strip
0.1 – 1.0 mm / 0.004" - 0.04"	0.1 – 0.6 mm / 0.004" - 0.024"



WARNING

Make sure the mechanical installation complies with the system requirements concerning distance, planarity and parallelism between the sensor and the scale as shown in Figure 2 all along the whole measuring length.

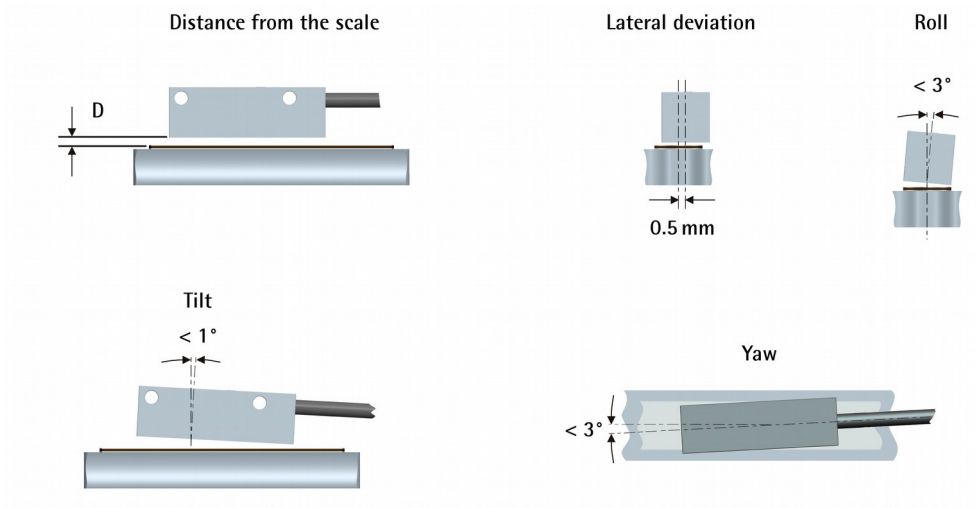
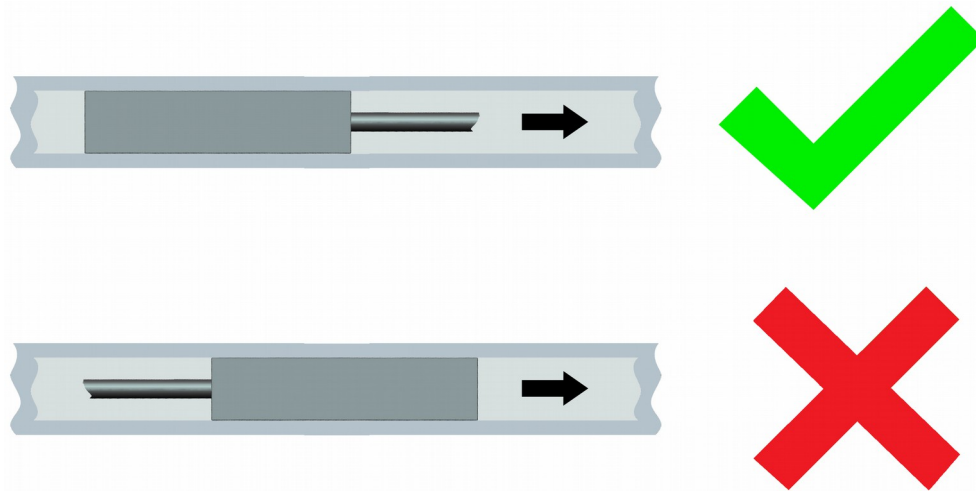

Figure 2



WARNING

After having installed the sensor on the magnetic scale a zero setting operation is compulsorily required. The zero setting operation is further required every time either the sensor or the scale is replaced. For further information refer to page 12.

4 - Electrical connections



WARNING

Electrical connection has to be carried out by qualified personnel only, with power supply disconnected and mechanical parts compulsorily in stop.



WARNING

If wires of unused signals come in contact, irreparable damage could be caused to the device. Please insulate them singularly.

Connections

Function	M12 8-pin	M8 cable
0Vdc	1	Black
+10Vdc +30Vdc	2	Red
CLOCK IN +	3	Yellow
CLOCK IN -	4	Blue
DATA OUT +	5	Green
DATA OUT -	6	Orange
Zero setting	7	White
Counting direction	8	Grey
Shield	Case	Shield

4.1 M12 8-pin connector specifications

M12 8-pin connector

male, frontal side

A coding

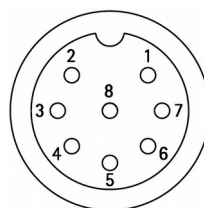

4.2 M8 cable specifications

Model : LIKA HI-FLEX M8 cable

Wires : 6 x 0.14 mm² + 2 x 0.22 mm²

Shield : tinned copper braid

Outer diameter : 5.3 ÷ 5.6 mm (0.21" ÷ 0.22")

Conductor resistance : 6 x 148 Ω/km, 2 x 90 Ω/km

Minimum bending radius : Ø x 7.5

4.3 Ground connection

Minimize noise by connecting the shield and/or the sensor to ground. Make sure that ground is not affected by noise. The connection point to ground can be situated both on the device side and on user's side. The best solution to minimize the interference must be carried out by the user.

4.4 Zero setting

The output value can be set to zero (reset) by means of an external signal sent by a PLC or other device. The internal microprocessor uses this signal to zero set the position information. Thus the position information will be "0" in the point where the operation is performed. Connect the Zero setting input to 0Vdc if not used. To zero set the value, connect the input to +Vdc for 100 μ s at least, then disconnect +Vdc. Normally voltage must be at 0Vdc. The reset must be performed when the sensor is in stop. You must set the Counting direction first and then zero set the encoder position.

4.5 Counting direction

The **standard counting direction** is to be intended with sensor moving as indicated by the arrow in Figure 1. This input allows to reverse the counting direction. In other words, it allows the count up when the sensor moves in the reverse of the standard direction, i.e. in the opposite direction to the one shown by the arrow in Figure 1. Connect the input to 0Vdc if not used. When the Counting direction input is connected to 0Vdc, the position information increases when the sensor moves according to the arrow in Figure 1. When the Counting direction input is connected to +Vdc, the position information increases when the sensor moves in reverse of the standard direction, i.e. in the opposite direction to the one shown by the arrow in Figure 1.



WARNING

A zero setting operation is required after setting the counting direction.

4.6 Features summary

Order code	Resolution mm
SMA5-GA-100-...	0.1
SMA5-GA-50-...	0.05
SMA5-GA-10-...	0.01
SMA5-GA-5-...	0.005

Max. scale length (max. measuring length)	5,100 mm (5,035 mm)
Pole pitch dimension	5 mm
Max. information (max. value)	20 bits (1,048,575)

5 - SSI interface

Order code: SMA5-GA-...

5.1 SSI (Synchronous Serial Interface)



SSI (the acronym for **Synchronous Serial Interface**) is a synchronous point-to-point serial interface engineered for unidirectional data transmission between one Master and one Slave. Developed in the first eighties, it is based on the RS-422 serial standard.

Its most peculiar feature is that data transmission is achieved by synchronizing both the Master and the Slave devices to a common clock signal generated by the controller; in this way the output information is clocked out at each controller's request. Furthermore only two pairs of twisted wires are used for data and clock signals, thus a six-wire cable is required.

The main advantages in comparison with parallel or asynchronous data transmissions are:

- less conductors are required for transmission;
- less electronic components;
- possibility of insulating the circuits galvanically by means of optocouplers;
- high data transmission frequency;
- hardware interface independent from the resolution of the absolute encoder.

Furthermore the differential transmission increases the noise immunity and decreases the noise emissions. It allows multiplexing from several encoders, thus process controls are more reliable with simplified line design and easier data management.

Data transmission is carried out as follows.

At the first falling edge of the clock signal (1, the logic level changes from high to low) the absolute position value is stored while at the following rising edge (2) the transmission of data information begins starting from the MSB.

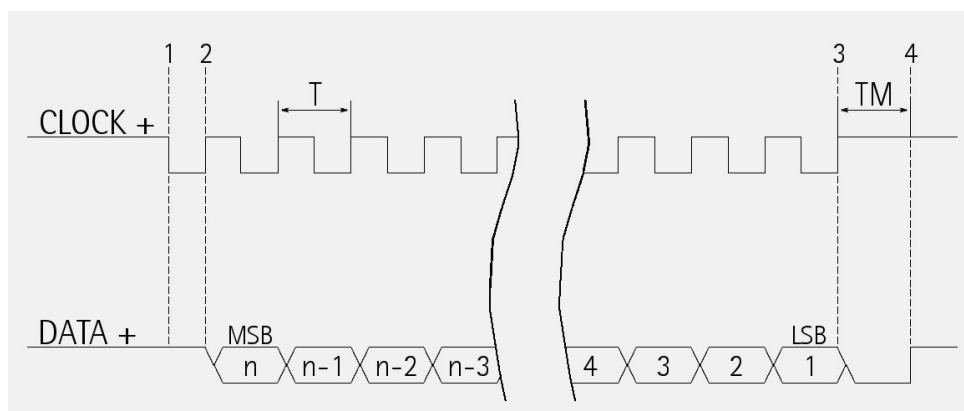

At each change of the clock signal and at each subsequent rising edge (2) one bit is clocked out at a time, up to LSB, so completing the data word transmission. The cycle ends at the last rising edge of the clock signal (3). This

means that up to $n + 1$ rising edges of the clock signals are required for each data word transmission (where n is the bit resolution); for instance, a 13-bit encoder needs 14 clock edges. If the number of clocks is greater than the number of bits of the data word, then the system will send a zero (low logic level signal) at each additional clock, zeros will either lead (LSB ALIGNED protocol) or follow (MSB ALIGNED protocol) or lead and/or follow (TREE FORMAT protocol) the data word. After the period T_m monoflop time, having a typical duration of 12 μ sec, calculated from the end of the clock signal transmission, the encoder is then ready for the next transmission and therefore the data signal is switched high.

The clock signal has a typical logic level of 5V, the same as the output signal which has customarily a logic level of 5V in compliance with RS-422 standard.

The output code can be either Binary or Gray (see the order code).

5.2 LSB right aligned protocol

"LSB right aligned" protocol allows to right align the bits, beginning from MSB (most significant bit) to LSB (least significant bit); LSB is then sent at the last clock cycle. Transmitted bits are always 25, the sensor uses a variable number of bits according to resolution. Unused bits are set to 0 (zero) and lead the data word:

Model	Resolution	Length of the word	Max. number of information
SMA5-GA-100-...	0.1 mm	25 bits	16 bits (65535)
SMA5-GA-50-...	0.05 mm	25 bits	17 bits (131071)
SMA5-GA-10-...	0.01 mm	25 bits	19 bits (524287)
SMA5-GA-5-...	0.005 mm	25 bits	20 bits (1048575)

The output code of the sensor is GRAY.

The length of each information is equal to the resolution (0.1 mm ... 0.005 mm).

Position information structure:

SMA5-GA-100-...	bits	25 ... 17	16	...	1
SMA5-GA-50-...	bits	25 ... 18	17	...	1
SMA5-GA-10-...	bits	25 ... 20	19	...	1
SMA5-GA-5-...	bits	25 ... 21	20	...	1
	value	00 ... 00	MSB	...	LSB

**WARNING**

The position value issued by the sensor is expressed in pulses; to convert the pulses into a metric measuring unit you must multiply the number of detected pulses by the resolution.

**EXAMPLE**

SMA5-GA-5-...

resolution = 5 μm

detected pulses = 123

position value = $123 * 5 = 615 \mu\text{m} = 0.615 \text{ mm}$

5.3 Recommended transmission rates

The SSI interface has a frequency of data transmission ranging between 100 kHz and 1.5 MHz.

The CLOCK signal and DATA signal comply with the "EIA standard RS-422".

The clock frequency (baud rate) depends on the length of the cable and must comply with the technical information reported in the following table:

Cable length	Baud rate
< 50 m	< 400 kHz
< 100 m	< 300 kHz
< 200 m	< 200 kHz
< 400 m	< 100 kHz

The time interval between two Clock sequence transmissions must be at least 30 μs ($T_p > 30 \mu\text{s}$).

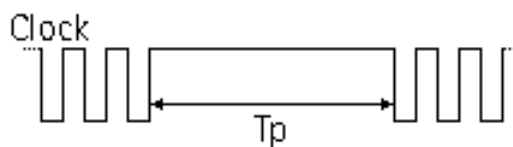

6 – Error and fault diagnostics

In case of wrong alignment between the sensor and the magnetic scale, at power on or during operation the following errors may occur:

- the LED lights up when switching on the system: there is a wrong alignment; position value 0 (zero) is transmitted until valid data is detected; please install the sensor properly; as soon as the sensor is aligned correctly the LED switches off;
- the LED lights up during operation: the last valid position is "frozen" (kept in memory) until the next valid position is detected on the scale.

6.1 Diagnostic LED

When the LED lights up, it indicates that an error is active, such as for instance an incorrect alignment between the sensor and the scale:

- the gap between the sensor and the scale is out of tolerance (see Figure 2)
- the sensor is not installed properly
- the sensor or the scale are installed upside down
- the sensor is installed in the opposite direction to the one shown in Figure 1
- the sensor is travelling too fast
- the power supply is not as required



NOTE

When the LED is off, this means that the sensor is working properly and the absolute position is output correctly.

For further information refer also to the "8 - Troubleshooting" section on page 19.

7 - Maintenance

The magnetic measurement system does not need any particular maintenance; anyway it has to be handled with the utmost care as any delicate electronic equipment. From time to time we recommend the following operations:

- periodically check the soundness of the structure and make sure that there are no loose screws; tighten them if necessary;
- check the gap between the sensor and the magnetic scale all along the whole measuring length. Wear of the machine may increase the tolerances;
- the surface of the magnetic scale has to be regularly cleaned using a soft and clean cloth to remove dust, chips, moisture etc.

8 - Troubleshooting

The following list shows some typical faults that may occur during installation and operation of the magnetic measurement system.

Fault

The system does not work (no pulse output)

- The scale and/or the sensor are not installed properly (the active surface of the scale does not match the sensitive part of the sensor). For correct installation please refer to the "3 - Mounting instructions" section on page 8. The diagnostic LED is lit.
- A magnetic part or a protection surface is interposed between the sensor and the scale. Only non-magnetic materials are allowed between the sensor and the scale. The diagnostic LED is lit.
- Installation does not comply with the tolerance gap between the sensor and the scale indicated in this guide; the sensor hits the surface of the scale or is too far from it. Check whether the sensor sensitive part is damaged.
- The sensor has been damaged by short circuit or wrong connection.

Fault

The measured values are either inaccurate or not provided in the whole length

- The gap between the sensor and the scale is not respected all along the whole measuring length. See the "3 - Mounting instructions" section on page 8.
- The sensor is not installed properly on the scale. See the "3 - Mounting instructions" section on page 8.
- The connection cable runs near high voltage cables or the shield is not connected properly. Check the earthing point.
- The frequency of the Master clock is set too high or too low and the transmission cannot be synchronized correctly. See the "5 - SSI interface" section on page 14.
- A section of the magnetic scale has been damaged mechanically or magnetically along the measuring length.
- The measuring error is caused by a torsion in the machine structure. Check parallelism and symmetry in the movement of the machine.

For further information refer also to the "6 - Error and fault diagnostics" section on page 17.

Document release	Release date	Description	HW	SW	Interface
1.0	04.11.2004	First issue			
1.1	02.12.2004	User's guide updated			
1.2	25.01.2005	User's guide updated			
1.3	12.10.2010	"5 - SSI interface" section updated			
1.4	04.09.2013	User's guide updated, "5 - SSI interface" section updated			
1.5	06.08.2014	General review, "3 - Mounting instructions" section updated			
1.6	13.11.2015	M12 8-pin connector added, installation with cover strip			
1.7	21.04.2016	General review			

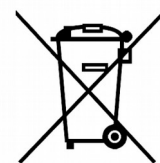

Dispose separately

lika

Lika Electronic

Via S. Lorenzo, 25 • 36010 Carrè (VI) • Italy

Tel. +39 0445 806600

Fax +39 0445 806699



info@lika.biz • www.lika.biz