

MDW Flexible Coupling - Disk Type

WEB Selection Tool WEB CAD Download 0 Zero Backlash SUS Stainless steel

Structure

● Clamping type

MDW-C

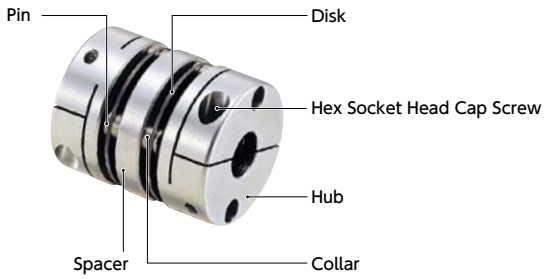

● Applicable motors..

	MDW
Servomotor	○
Stepping motor	○
General-purpose motor	○

○: Excellent ○: Very good

● Property

	MDW
Zero Backlash	○
Allowable Misalignment	○

○: Excellent ○: Very good

- This is a disk type flexible coupling.
- The stainless steel disk allows the eccentricity, and angular misalignment, and end-play.

● Application

Actuator/XY stage

● Material/Finish

RoHS2 Compliant

	MDW-C
Hub	A2017 Alumite Treatment
Spacer	A2017 Alumite Treatment
Disk	SUS304
Pin	SUS303
Collar	SUS303
Hex Socket Head Cap Screw	SCM435 Ferrosoferric oxide film

● Comparison of static torsional stiffness (disk-type)

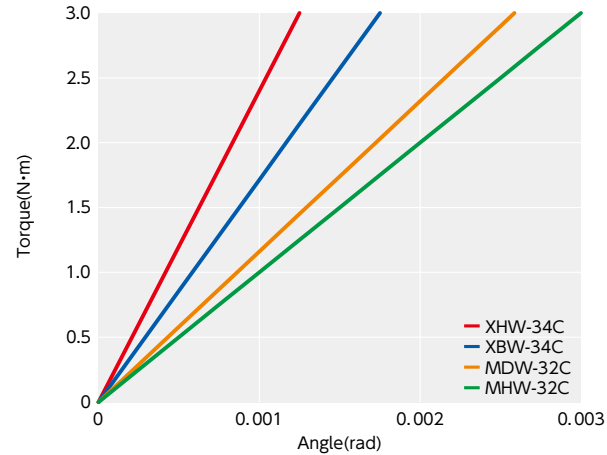

MDW-C

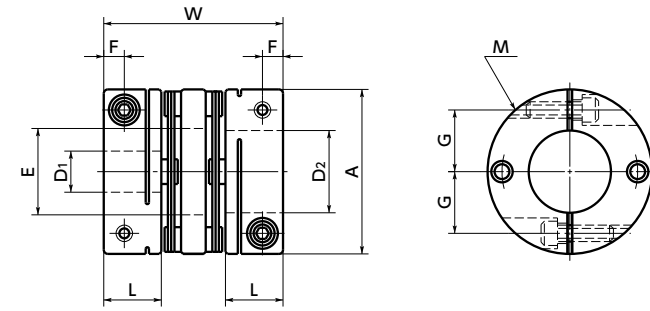

Dimensions

Unit: mm

Part Number	A	L	W	E	F	G	M	Screw Tightening Torque (N·m)
MDW-19C	19	8	27	8.5	2.5	6.5	M2	0.5
MDW-25C	25	10	31	12.5	3.5	9	M2.5	1
MDW-32C	32	12	40	16	4	11	M3	1.5
MDW-40C	40	14	44	21	5	15	M4	2.5
MDW-50C	50	18	57	26	6	18	M5	7
MDW-63C	63	20	61	35	7	24	M6	12

Part Number	Standard Bore Diameter D1 · D2																						
	4	5	6	6.35	7	8	9	10	11	12	14	15	16	17	18	19	20	22	24	25	28	30	
MDW-19C	●	●	●		●	●																	
MDW-25C			●	●		●	●	●	●	●													
MDW-32C						●	●	●	●	●	●	●											
MDW-40C						●	●	●	●	●	●	●	●	●	●	●	●						
MDW-50C										●	●	●	●	●	●	●	●	●	●	●	●	●	●
MDW-63C												●	●	●	●	●	●	●	●	●	●	●	●

- All products are provided with hex socket head cap screw.
- Recommended dimensional allowances of applicable shaft diameter are h6 and h7.
- In case of mounting on D-cut shaft, be careful about the position of the D-cut surface of the shaft. → P.258

Performance

Part Number	Max. Bore Diameter (mm)	Rated*1 torque (N·m)	Max. Rotational Frequency (min ⁻¹)	Moment*2 of Inertia (kg·m ²)	Static Torsional Stiffness (N·m/rad)	Max. Lateral Misalignment (mm)	Max. Angular Misalignment (°)	Max. Axial Misalignment (mm)	Mass*2 (g)
MDW-19C	8	0.7	33000	8.7×10 ⁻⁷	200	0.12	1.5	±0.5	18
MDW-25C	12	1	25000	2.7×10 ⁻⁶	450	0.12	1.5	±0.5	25
MDW-32C	15	2.5	19000	9.6×10 ⁻⁶	1100	0.15	1.5	±0.5	60
MDW-40C	20	3.5	15000	1.9×10 ⁻⁵	1400	0.15	1.5	±0.5	100
MDW-50C	25	9	12000	8.1×10 ⁻⁵	2200	0.15	1.5	±0.5	210
MDW-63C	30	12.5	10000	2.1×10 ⁻⁴	3000	0.15	1.5	±0.5	340

*1: Correction of rated torque due to load fluctuation is not required.
*2: These are values with max. bore diameter.

● Related Products

The Double-Disk type Flexible Coupling **XHW** is compatible with the servomotor with 350% instantaneous max. torque is available.
→ P.65



● Part number specification

MDW-25C-6-8

1 2

Structure

Clamping type

MDS-C

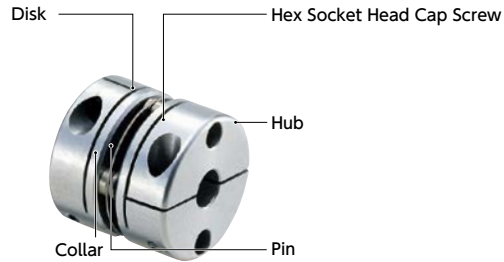

Material/Finish

RoHS2 Compliant

	MDS-C
Hub	A2017 Alumite Treatment
Disk	SUS304
Pin	SUS303
Collar	SUS303
Hex Socket Head Cap Screw	SCM435 Ferrosoferric oxide film

Comparison of static torsional stiffness (single disk-type)

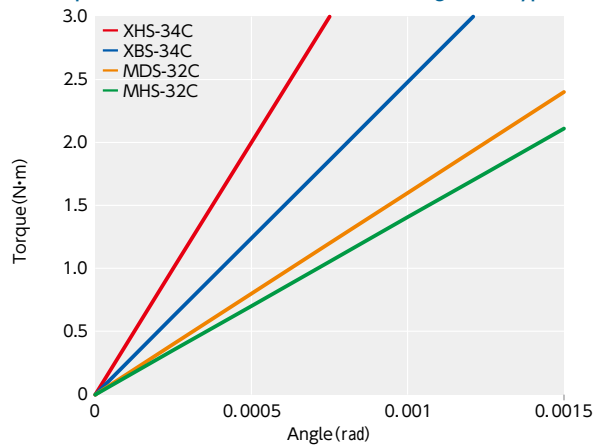

Applicable motors

	MDS
Servomotor	⊙
Stepping motor	⊙
General-purpose motor	⊙

⊙: Excellent ○: Very good

Property

	MDS
Zero Backlash	⊙
Allowable Misalignment	○

⊙: Excellent ○: Very good

- This is a disk type flexible coupling.
- It has compact design with short entire length.
- The stainless steel disk allows the eccentricity, and angular misalignment, and end-play.

Application

Actuator/XY stage

MDS-C

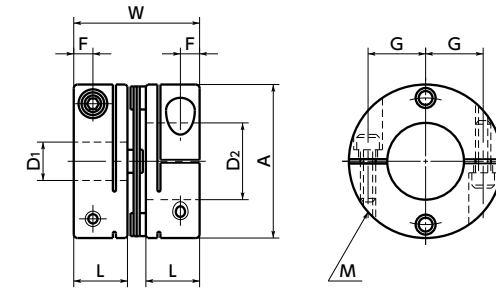

Dimensions

Unit: mm

Part Number	A	L	W	F	G	M	Screw Tightening Torque (N·m)
MDS-19C	19	8	20	2.5	6.5	M2	0.5
MDS-25C	25	10	24	3.5	9	M2.5	1
MDS-32C	32	12	29	4	11	M3	1.5
MDS-40C	40	14	33	5	15	M4	2.5
MDS-50C	50	18	42	6	18	M5	7
MDS-63C	63	20	46	7	24	M6	12

Part Number	Standard Bore Diameter																								
	D1	D2	4	5	6	6.35	7	8	9	10	11	12	14	15	16	17	18	19	20	22	24	25	28	30	
MDS-19C	●	●	●	●	●	●	●	●																	
MDS-25C			●	●	●	●	●	●	●	●	●	●													
MDS-32C								●	●	●	●	●	●	●	●	●	●	●	●	●	●	●	●	●	●
MDS-40C								●	●	●	●	●	●	●	●	●	●	●	●	●	●	●	●	●	●
MDS-50C													●	●	●	●	●	●	●	●	●	●	●	●	●
MDS-63C														●	●	●	●	●	●	●	●	●	●	●	●

- All products are provided with hex socket head cap screw.
- Recommended dimensional allowances of applicable shaft diameter are h6 and h7.
- In case of mounting on D-cut shaft, be careful about the position of the D-cut surface of the shaft. → P.258

Performance

Part Number	Max. Bore Diameter (mm)	Rated*1 torque (N·m)	Max. Rotational Frequency (min ⁻¹)	Moment*2 of Inertia (kg·m ²)	Static Torsional Stiffness (N·m/rad)	Max. Lateral Misalignment (mm)	Max. Angular Misalignment (°)	Max. Axial Misalignment (mm)	Mass*2 (g)
MDS-19C	8	0.7	33000	6.3×10 ⁻⁷	280	0.02	0.7	±0.2	9
MDS-25C	12	1	25000	2.1×10 ⁻⁶	630	0.02	0.7	±0.2	19
MDS-32C	15	2.5	19000	7.2×10 ⁻⁶	1600	0.02	0.7	±0.2	41
MDS-40C	20	3.5	15000	1.3×10 ⁻⁵	2600	0.02	0.7	±0.2	68
MDS-50C	25	9	12000	6.1×10 ⁻⁵	3100	0.02	0.7	±0.2	140
MDS-63C	30	12.5	10000	1.7×10 ⁻⁴	4200	0.02	0.7	±0.2	250

- *1: Correction of rated torque due to load fluctuation is not required.
- *2: These are values with max. bore diameter.

Related Products

The Single-Disk type Flexible Coupling [XHS] is compatible with the servomotor with 350% instantaneous max. torque is available. → P.71



Part number specification

MDS-32C-10-12

1 2