

**Structure**

● Set Screw type

**MOL** Outside diameter  $\phi 16 - \phi 32 \rightarrow$  P.189

Hex Socket Set Screw



**MOL** Outside diameter  $\phi 40 - \phi 63$



**MOS**  $\rightarrow$  P.191

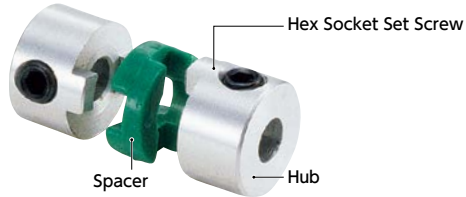

● Clamping type

**MOL-C** Outside diameter  $\phi 16 - \phi 32 \rightarrow$  P.189

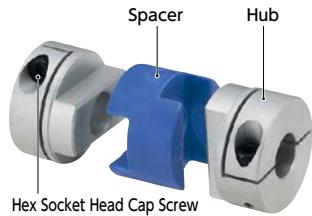

**MOL-C** Outside diameter  $\phi 40 - \phi 63$



**MOS-C**  $\rightarrow$  P.191

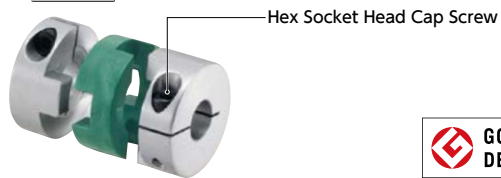

● Applicable motors

	MOL	MOS
Servomotor	-	-
Stepping Motor	○	○
General-purpose motor	◎	◎

◎: Excellent ○: Very good

● Property

	MOL	MOS
Allowable Misalignment	◎	◎
Electrical insulation	◎	◎
Allowable operating temperature	-20°C to 80°C	-20°C to 80°C

◎: Excellent ○: Very good

- This is an oldham-type flexible coupling.
- Slippage of hubs and a spacer allows large eccentricity and angular misalignment to be accepted.
- The load on the shaft generated by misalignment is small and the burden on the shaft is reduced.
- It has electrical insulation.
- Standard type **MOL** and short type **MOS** are available.

● Application

Parts feeder/Transport device

● Material/Finish

RoHS2 Compliant

	MOL / MOL-C / MOS / MOS-C
Hub	A2017 Alumite Treatment
Spacer	Polyacetal
Hex Socket Set Screw	SCM435 Ferrosferric oxide film
Hex Socket Head Cap Screw	SCM435 Ferrosferric oxide film

● Related Products

Oldham-type coupling with high torque specification **MOR** is available.

$\rightarrow$  P.161



Oldham-type couplings **MOM** with metal spacers are available.

$\rightarrow$  P.173



● Part number specification

**MOL-20C-6-8**

Product Code    Size    Bore Diameter

Please refer to dimensional table for part number specification.

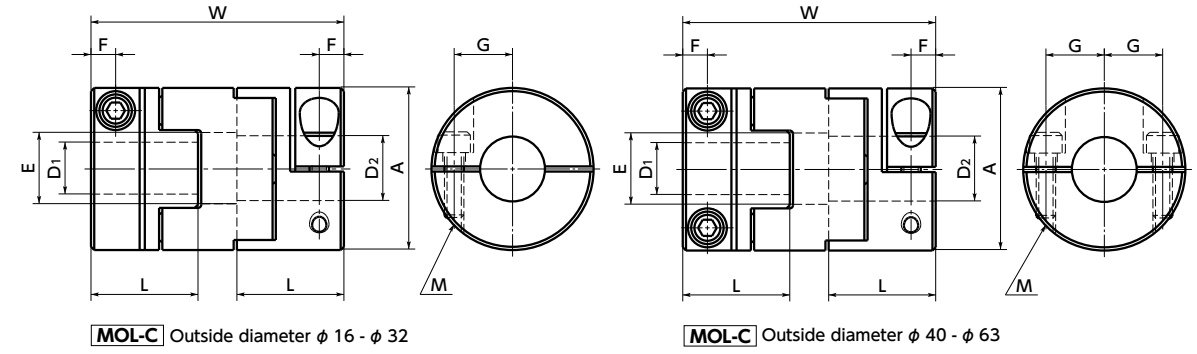
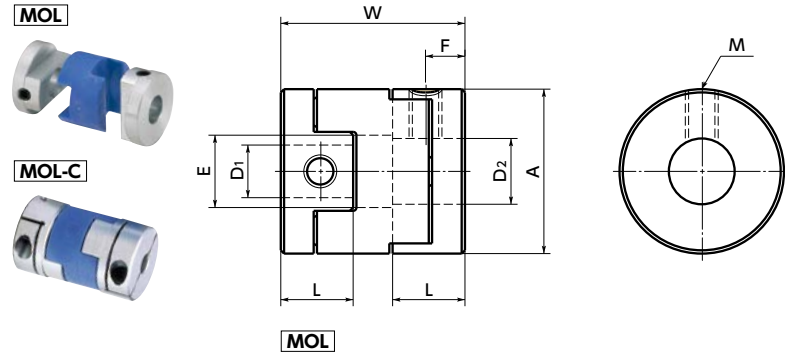

**Dimensions**

Unit : mm

Part Number	A	L	W	E	F	G	M	Screw Tightening Torque (N·m)
MOL-16	16	7	18	7	3.5		M3	0.7
MOL-20	20	9	23	9	4.5		M4	1.7
MOL-25	25	11	28.2	11	5.5		M5	4
MOL-32	32	12.7	32.7	14.5	6.5		M6	7
MOL-40	40	14	32	17	7		M6	7
MOL-50	50	17	38.2	23	8.5		M8	15
MOL-63	63	21	46.6	28	10.5		M10	30
MOL-16C	16	12.5	29	7	3	5	M2.5	1
MOL-20C	20	14.4	33.8	9	3	6.5	M2.5	1
MOL-25C	25	16.5	39.2	11	3.8	9	M3	1.5
MOL-32C	32	18.7	44.7	14.5	4.5	11	M4	2.5
MOL-40C	40	23	50	17	7	13	M5	4
MOL-50C	50	27	58.2	23	8	16	M6	8
MOL-63C	63	33	70.6	28	10	21	M8	16

Part Number	Standard Bore Diameter																
	D1 · D2	3	4	5	6	6.35	8	9.525	10	11	12	14	15	16	18	20	25
MOL-16	●	●	●	●	●	●											
MOL-20		●	●	●	●	●											
MOL-25			●	●	●	●	●										
MOL-32					●			●		●							
MOL-40								●		●	●	●	●				
MOL-50										●	●	●	●	●	●	●	
MOL-63													●	●	●	●	●
MOL-16C			●	●													
MOL-20C				●	●	●											
MOL-25C					●	●		●									
MOL-32C						●		●	●								
MOL-40C									●	●	●						
MOL-50C												●	●	●	●	●	
MOL-63C													●	●	●	●	●

- All products are provided with hex socket set screw **MOL** or hex socket head cap screw **MOL-C**
- The dimensional allowance for bore diameter of a set screw type **MOL** is H8.
- Recommended dimensional allowances of applicable shaft diameter are h6 and h7.
- A set of hubs with set screw type for one side and clamping type for the other side is available upon request.
- In case of mounting on D-cut shaft, be careful about the position of the D-cut surface of the shaft. → P.258

Additional Keyway at Shaft Hole → P.803 | Cleanroom Wash & Packaging → P.807 | Change to Stainless Steel Screw → P.805

**Performance**

Part Number	Max. Bore Diameter (mm)	Rated*1 torque (N·m)	Max.*1 torque (N·m)	Max. Rotational Frequency (min <sup>-1</sup> )	Moment*2 of Inertia (kg·m <sup>2</sup> )	Static Torsional Stiffness (N·m/rad)	Max. Lateral Misalignment (mm)	Max. Angular Misalignment (°)	Mass*2 (g)
MOL-16	6.35	0.7	1.4	39000	3.2×10 <sup>-7</sup>	31	1	3	7
MOL-20	8	1.2	2.4	31000	1.0×10 <sup>-6</sup>	60	1.5	3	14
MOL-25	10	2	4	25000	3.0×10 <sup>-6</sup>	140	2	3	27
MOL-32	14	4.5	9	19000	9.5×10 <sup>-6</sup>	280	2.5	3	50
MOL-40	16	9	18	15000	2.3×10 <sup>-5</sup>	540	3	3	80
MOL-50	20	18	36	12000	6.7×10 <sup>-5</sup>	820	3.5	3	150
MOL-63	25	36	72	10000	2.2×10 <sup>-4</sup>	1900	4	3	300
MOL-16C	6	0.7	1.4	39000	5.8×10 <sup>-7</sup>	31	1	3	12
MOL-20C	8	1.2	2.4	31000	1.5×10 <sup>-6</sup>	60	1.5	3	19
MOL-25C	10	2	4	25000	4.4×10 <sup>-6</sup>	140	2	3	36
MOL-32C	14	4.5	9	19000	1.4×10 <sup>-5</sup>	280	2.5	3	69
MOL-40C	16	9	18	15000	4.1×10 <sup>-5</sup>	540	3	3	130
MOL-50C	20	18	36	12000	1.2×10 <sup>-4</sup>	820	3.5	3	230
MOL-63C	25	36	72	10000	3.7×10 <sup>-4</sup>	1900	4	3	450

- \*1 : Values with no load fluctuation and rotation in a single direction. If there is large load fluctuation, or both normal and reverse rotation, select a size with some margin. If ambient temperature exceeds 30°C, be sure to correct the rated torque and max. torque with temperature correction factor shown in the following table. The allowable operating temperature of **MOL** **MOL-C** is -20°C to 80°C.
- \*2 : These are values with max. bore diameter.

● Comparison of rated torque

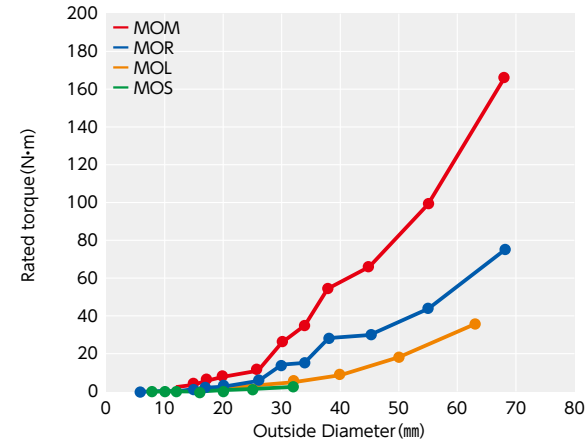

● Ambient Temperature / Temperature Correction Factor

Ambient temperature	Temperature correction factor
-20°C to 30°C	1.00
30°C to 40°C	0.80
40°C to 60°C	0.70
60°C to 80°C	0.55

● Part number specification

**MOL-40C-14-15** 1 set

**MOL - 40 - SPCR** Single Spacer

Product Code | Outside Diameter (A Dimension) | Single Spacer