

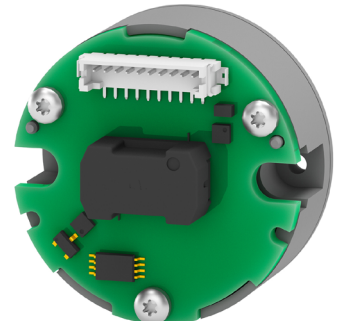

- Energy harvesting technology (no battery)
- Singleturn resolution up to 18 bit
- Absolute multiturn up to 24 bit
- Robust magnetic sensing
- BiSS-C or SSI interface
- Operating temperature up to 115°C

Applications:

- Servomotor feedback
- Robotics
- Drones/UAV
- Electromedical devices



AMM33

ENVIRONMENTAL SPECIFICATIONS

Shock:	200 g, 6 ms acc. to CEI EN 60068-2-27
Vibrations:	10 g, 10-2000 Hz acc. to CEI EN 60068-2-6
Protection:	IP00
Operating temperature range:	-40°C +115°C (-40°F +239°F)
Storage temperature range:	-25°C +85°C (-13°F +185°F)

MECHANICAL SPECIFICATIONS

Dimensions:	see drawing
Hollow shaft diameter:	Ø6 mm
Shaft rotational speed:	12000 rpm max. (mechanical)
Axial shaft run-out:	±0,2 mm max.
Radial shaft run-out:	±0,2 mm max.
Electrical connections:	PCB connector (connection cable to be ordered separately)
Weight:	~ 22 g (0,77 oz) (without connection cable)

ELECTRICAL SPECIFICATIONS

Resolution:	18 bit (262144 cpr) x 24 bit (16777216 rev.) max.
Accuracy:	< ±0,1° typ. factory calibration
Output circuit:	BiSS-C (clock max. 10MHz) SSI (clock 100 kHz ÷ 2MHz, T _p = 20µs)
Power supply:	+5Vdc ± 10%
Power consumption:	typ. 55 mA
EMC:	electro-magnetic immunity, EN 61000-4-2
Functions:	• Electronic zero setting (input)

MATERIALS

Encoder body:	fibre glass epoxy resin + PCB
Shaft hub:	stainless steel, non-magnetic, UNI EN 4305

ACCESSORIES

EC-DF13-LK-TF12-1:	Connection cable, 1 m
--------------------	-----------------------

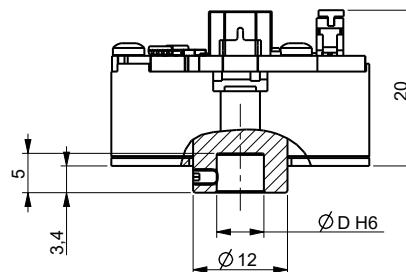
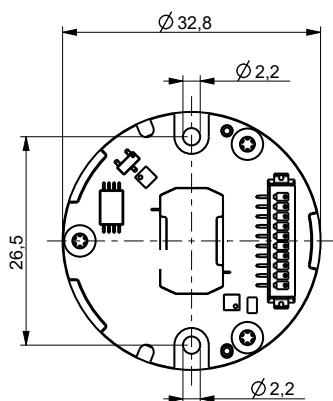

AMM33

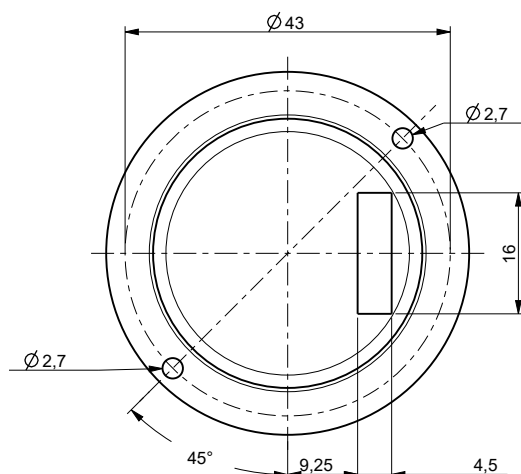
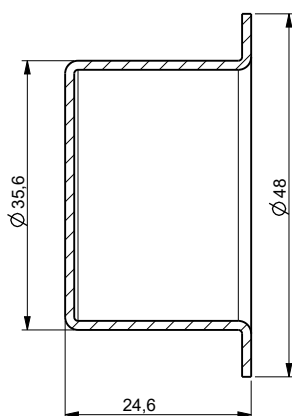

Magnetic shielding information

External magnetic interference might be present, depending on the application and the operating environment. To minimize or eliminate the influence on the operation of the encoder a proper shielding is recommended and shown in the figure.

Order code

AMM33	XX ⓐ	/	XXX ⓑ	XXX ⓒ	-	X ⓓ	-	XX ⓔ	/Sxxx ⓕ
-------	---------	---	----------	----------	---	--------	---	---------	------------

<p>ⓐ RESOLUTION</p> <p>13 = 13 bit (8192 cpr)</p> <p>16 = 16 bit (65536 cpr)</p> <p>18 = 18 bit (262144 cpr)</p>	<p>ⓑ REVOLUTION</p> <p>12 = 4096 turns</p> <p>16 = 65536 turns</p> <p>24 = 16777216 turns</p>	<p>ⓒ INTERFACE</p> <p>SC1 = BiSS-C</p> <p>BG1 = SSI, binary MSB aligned</p> <p>ⓓ SHAFT TYPE</p> <p>6 = $\varnothing 6$ mm hollow</p>	<p>ⓔ CONNECTIONS</p> <p>X1 = Hirose flat connector (mating type: DF13-10S-1.25C)</p> <p>ⓕ CUSTOM VERSION</p>
--	---	---	--

Document release	Date	Description
1.1	26.08.2022	Electrical specifications update
1	20.01.2022	First release