

DRAW-WIRE

Programmable incremental draw-wire encoder

lika

Series

SFEM1 • SFEM2



- Integrated programmable encoder
- Universal output circuit HTL/TTL
- Compact design & easy installation
- 5000 & 10000 mm measuring length
- Resolution up to 16384 PPR (progr.) or pre-programmed 0.05, 0.1, 0.2 mm



SFEM1 • SFEM2

ENVIRONMENTAL SPECIFICATIONS

Shock:	100 g, 6 ms
Vibrations:	10 g, 5-2000 Hz
Protection:	IP65
Operating temperature range:	-40°C +85°C (-40°F +185°F)
Storage temperature range:	-40°C +100°C (-40°F +212°F) (98% R.H. without condensation)

MECHANICAL SPECIFICATIONS

Dimensions:	see drawing
Drum circumference:	200 mm
Wire retraction force:	5000: 3,2 ÷ 6,5 N 10000: 3,2 ÷ 6 N
Measuring length:	5000, 10000 mm
Linearity:	± 0,5 mm
Repeatability:	± 0,1 mm (or ± 1 digit with resolution <2000)
Measuring speed:	2 m/sec max.
Weight:	~ 0,8 kg
Connections:	M12, M23 plug or cable output 1 m

ELECTRICAL SPECIFICATIONS

Power supply:	+5Vdc +30Vdc
Output circuit:	Universal circuit PP/LD
Resolution:	0.05, 0.1, 0.2 mm or programmable (16384 PPR max.)
Output current:	40 mA max.
Input current:	60 mA max.
Output signals:	AB0, /AB0

MATERIALS

Housing (draw-wire):	anticorodal, UNI EN AW-6082
Housing (encoder):	die cast aluminium, UNI EN AC-46100
Wire:	stainless steel, non magnetic - UNI EN 4305

ACCESSORIES

EPFL 121:	M23 12 pin mating connector
EC-C12F-LK-I8-5:	M23 cordset with 5 m cable
EC-C12F-LK-I8-10:	M23 cordset with 10 m cable
E-M12F12:	M12 12 pin mating connector
EC-M12F12-LK-T12-5:	M12 cordset with 5 m cable*
EC-M12F12-LK-T12-10:	M12 cordset with 10 m cable*
KIT IP/IQ58:	USB programming kit
EC-IP/IQ58-M23:	M23 programming cable
EC-IP/IQ58-M12:	M12 programming cable

* Cannot be used as programming cable

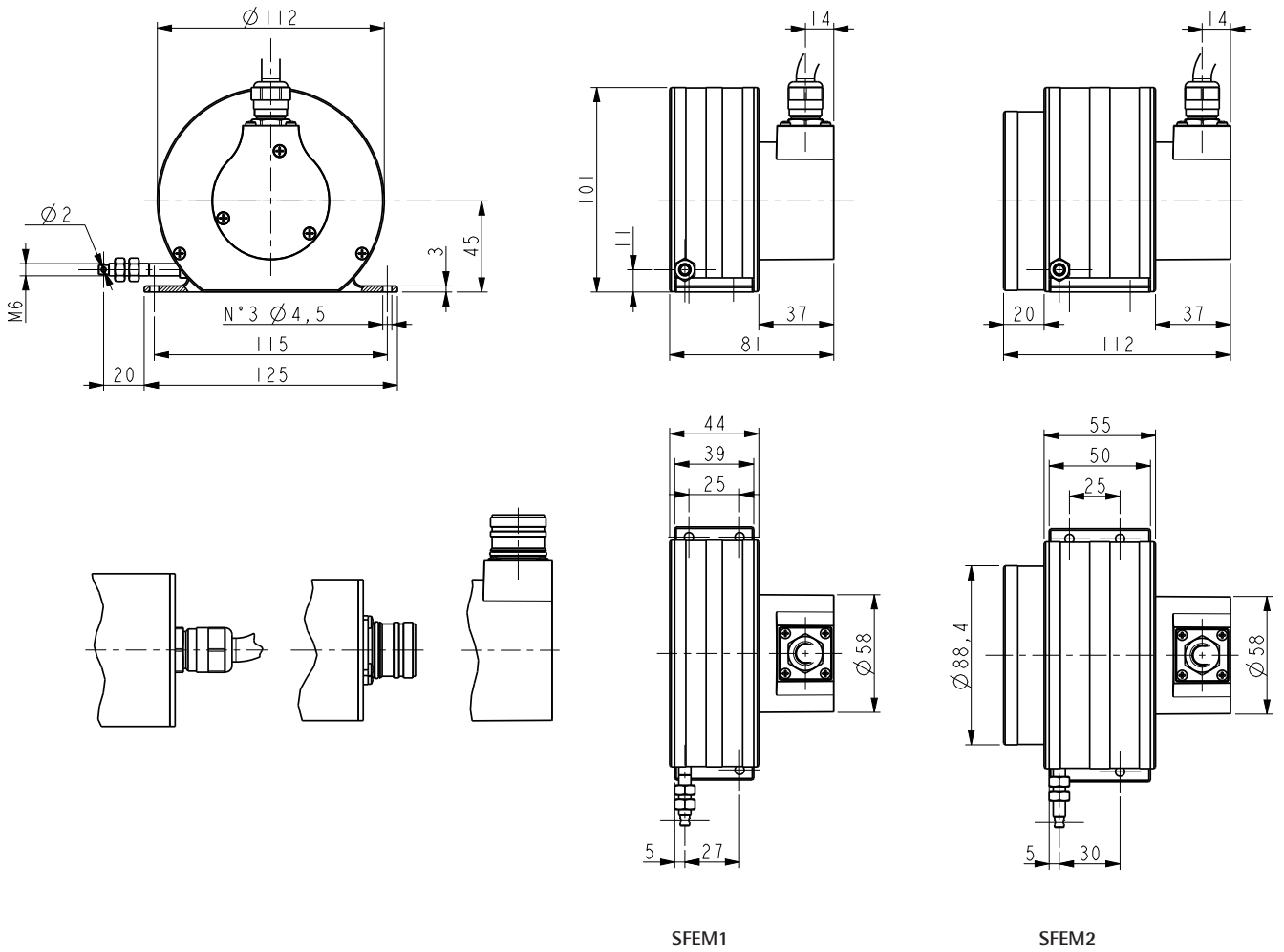

Order code

SFEM1	-	XXXXX	-	XX	-	XXXXX	-	X	-	XXXX	/Sxxx
SFEM2		Ⓐ		Ⓑ		Ⓒ		Ⓓ		Ⓔ	Ⓕ

Ⓐ MEASURING LENGTH

05000 = 5000 mm (SFEM1)
10000 = 10000 mm (SFEM2)

Ⓑ OUTPUT CIRCUIT / POWER SUPPLY

H4 = PP/LD universal circuit, +5Vdc +30Vdc

Ⓒ RESOLUTION

04000 = 0,05 mm
02000 = 0,1 mm
01000 = 0,2 mm
00PRG = programmable (0,01 mm max.)

Ⓓ CONNECTION POSITION

A = axial
R = radial

Ⓔ CABLE TYPE & LENGTH

L010 = cable output 1 m
Lxx0 = cable output x m (max. length 10 m)
M1 = M12 12 pin plug
M2 = M23 12 pin plug

Ⓕ CUSTOM VERSION

Document release	Date	Description
1.2	03.11.2023	Cable type (M1)
1.1	02.10.2023	Cable type (M8)
1.0	September 2023	New order code