

- Giunto elastico per impiego universale
- Ricavato dal pieno
- Assorbe vibrazioni

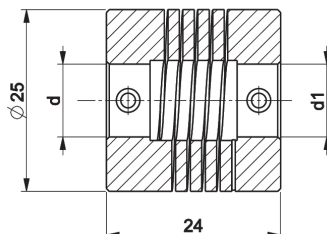
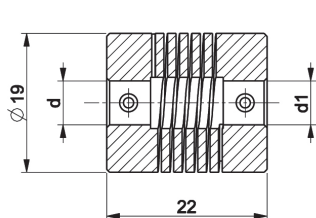

PAN

CARATTERISTICHE

Serie	Diametro interno d - d1 mm	Coppia max. (Nm)	Numero giri max. (rpm)	Momento d'inerzia (gcm ²)	Rigidità torsionale (Nm/rad)	Disallineamento radiale max. (mm)	Disallineamento angolare max. (°)	Disallineamento assiale max. (mm)	Peso (g)
PAN-6	6 - 6	0,6	8000	6,7	9	±0,25	±3,5	±0,4	13
PAN-8	8 - 8	1	8000	22	20	±0,3	±4	±0,5	26
PAN-10	10 - 10	1	8000	22	20	±0,3	±4	±0,5	26
PAN-12	12 - 12	1	8000	22	20	±0,3	±4	±0,5	26

- Mozzi in metallo, elemento flessibile in polimero
- Assorbe elevati disallineamenti
- Isolamento elettrico degli alberi

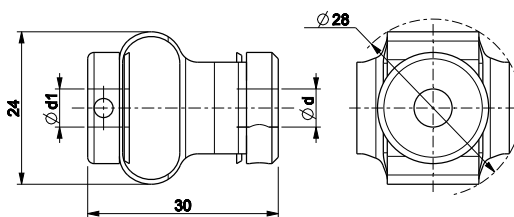

PGF

CARATTERISTICHE

Serie	Diametro interno d - d1 mm	Coppia max. (Nm)	Numero giri max. (rpm)	Momento d'inerzia (gcm ²)	Rigidità torsionale (Nm/rad)	Disallineamento radiale max. (mm)	Disallineamento angolare max. (°)	Disallineamento assiale max. (mm)	Peso (g)
PGF-6	6 - 6	0,5	3000	10	3,2	±2,5	±6	±3	20
PGF-6-7	6 - 7	0,5	3000	10	3,2	±2,5	±6	±3	20
PGF-6-8	6 - 8	0,5	3000	10	3,2	±2,5	±6	±3	20
PGF-6-10	6 - 10	0,5	3000	10	3,2	±2,5	±6	±3	20
PGF-7-7	7 - 7	0,5	3000	10	3,2	±2,5	±6	±3	20
PGF-7-8	7 - 8	0,5	3000	10	3,2	±2,5	±6	±3	20
PGF-8	8 - 8	0,5	3000	10	3,2	±2,5	±6	±3	20
PGF-8-10	8 - 10	0,5	3000	10	3,2	±2,5	±6	±3	20
PGF-10	10 - 10	0,5	3000	10	3,2	±2,5	±6	±3	20

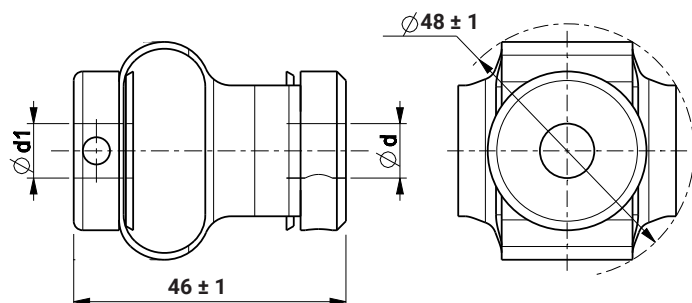

PGFPLUS-20

CARATTERISTICHE

Serie	Diametro interno d - d1 mm	Coppia max. (Nm)	Numero giri max. (rpm)	Momento d'inerzia (gcm ²)	Rigidità torsionale (Nm/rad)	Disallineamento radiale max. (mm)	Disallineamento angolare max. (°)	Disallineamento assiale max. (mm)	Peso (g)
PGFPLUS-20-10-10	10-10	2	3000	110	28	±3	±12	±4	85
PGFPLUS-20-12-12	12-12	2	3000	110	28	±3	±12	±4	85
PGFPLUS-20-14-14	14-14	2	3000	110	28	±3	±12	±4	85

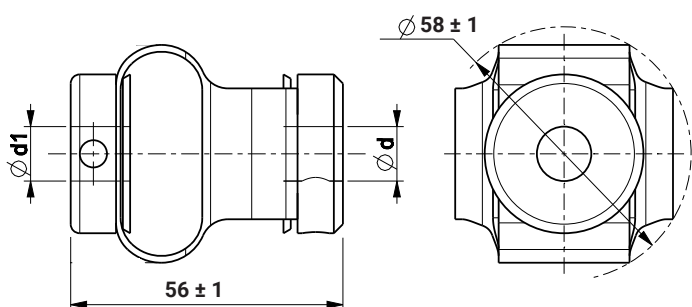

PGFPLUS-30

CARATTERISTICHE

Serie	Diametro interno d - d1 mm	Coppia max. (Nm)	Numero giri max. (rpm)	Momento d'inerzia (gcm ²)	Rigidità torsionale (Nm/rad)	Disallineamento radiale max. (mm)	Disallineamento angolare max. (°)	Disallineamento assiale max. (mm)	Peso (g)
PGFPLUS-30-10-10	10-10	5	3000	220	43	±5	±15	±5	140
PGFPLUS-30-12-12	12-12	5	3000	220	43	±5	±15	±5	140
PGFPLUS-30-14-14	14-14	5	3000	220	43	±5	±15	±5	140
PGFPLUS-30-16-16	16-16	5	3000	220	43	±5	±15	±5	140
PGFPLUS-30-18-18	18-18	5	3000	220	43	±5	±15	±5	140

Versione documento	Data release	Descrizione
1.1	01.06.2021	Cancellati i modelli: PGF 9,52-9,52 e PGF 9,52-10